

NEU2168GKA

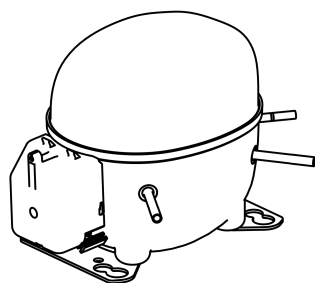

ENGINEERING CODE
955AA76

REFRIGERANT
R-404A

POWER SUPPLY
220-240 V 50 Hz

APPLICATION
LBP

MOTOR TYPE
CSIR

STANDARD
ASHRAE

COOLING CAPACITY
731 W

EFFICIENCY
1.34 W/W

DATA

GENERAL DATA

Model	NEU2168GKA
Type	Hermetic Reciprocating
Technology	ON/OFF
Compressor Application	LBP
Expansion Device	Capillary Tube or Expansion Valve
Compressor Cooling	Fan/220
HP	3/4
Starting Torque	HST
Plant	SLOVAKIA

ELECTRICAL DATA

Start Winding Resistance	12.02 Ω at 25°C
Run Winding Resistance	5.15 Ω at 25°C
Locked Rotor Amperage (LRA) 50Hz	24.8 A
Rated Load Amperage (LMBP) at 50 Hz	3.6 A

MECHANICAL DATA

Displacement	13.54 cm ³
Oil Charge	350 ml
Oil Type	ESTER
Oil Viscosity	ISO22
Weight	11.1 Kg

ELECTRICAL COMPONENTS

Start Capacitor	108-130 μf/330 V
CSR CSIR BOX	No
Starting Device Type	RELAY
Starting Device Description	213515047*
Overload Protection	USP-M1E-83 (internal)

PERFORMANCE

TESTED CONDITIONS

Tested Refrigerant	R-404A
Tested Application	LBP
Tested Standard	ASHRAE
Tested Cooling	Fan
Tested Voltage	220 V
Refrigerant Temperature	Dew

RATED POINTS

Condensing Temperature °C	Evaporating Temperature °C	Cooling Capacity W	Efficiency W/W	Power Consumption W	Current A	Gas Flow Rate kg/h
54.4	-23.3	731	1.34	547	3.26	16.9

Test Condition: Liquid 32.2 °C, Return Gas 32.2 °C. Data generated in accordance to EN 12900:2013 polynomial equation and tolerance guidelines.

PERFORMANCE CURVE

Condensing Temperature 35°C

Evaporating Temperature °C	Cooling Capacity W	Efficiency W/W	Power Consumption W	Current A	Gas Flow Rate kg/h
-40	338	1.06	318	2.62	7.74
-35	457	1.24	368	2.74	10.52
-30	604	1.44	420	2.88	13.94
-25	779	1.65	472	3.03	18.07
-20	985	1.88	524	3.20	22.95
-15	1222	2.13	574	3.39	28.64
-10	1492	2.41	620	3.60	35.22

Test Condition: Liquid 32.2 °C, Return Gas 32.2 °C. Data generated in accordance to EN 12900:2013 polynomial equation and tolerance guidelines.

PERFORMANCE CURVE

Condensing Temperature 45°C

Evaporating Temperature °C	Cooling Capacity W	Efficiency W/W	Power Consumption W	Current A	Gas Flow Rate kg/h
-40	299	0.93	320	2.64	6.84
-35	414	1.10	378	2.77	9.51
-30	557	1.27	440	2.93	12.82
-25	727	1.44	505	3.12	16.82
-20	928	1.62	572	3.34	21.58
-15	1160	1.81	639	3.59	27.14
-10	1425	2.02	706	3.88	33.57

Test Condition: Liquid 32.2 °C, Return Gas 32.2 °C. Data generated in accordance to EN 12900:2013 polynomial equation and tolerance guidelines.

PERFORMANCE CURVE

Condensing Temperature 55°C

Evaporating Temperature °C	Cooling Capacity W	Efficiency W/W	Power Consumption W	Current A	Gas Flow Rate kg/h
-30	498	1.12	444	2.94	11.46
-25	663	1.28	520	3.17	15.32
-20	858	1.43	601	3.45	19.92
-15	1085	1.58	685	3.77	25.33
-10	1345	1.75	770	4.14	31.61

Test Condition: Liquid 32.2 °C, Return Gas 32.2 °C. Data generated in accordance to EN 12900:2013 polynomial equation and tolerance guidelines.

ENVELOPE

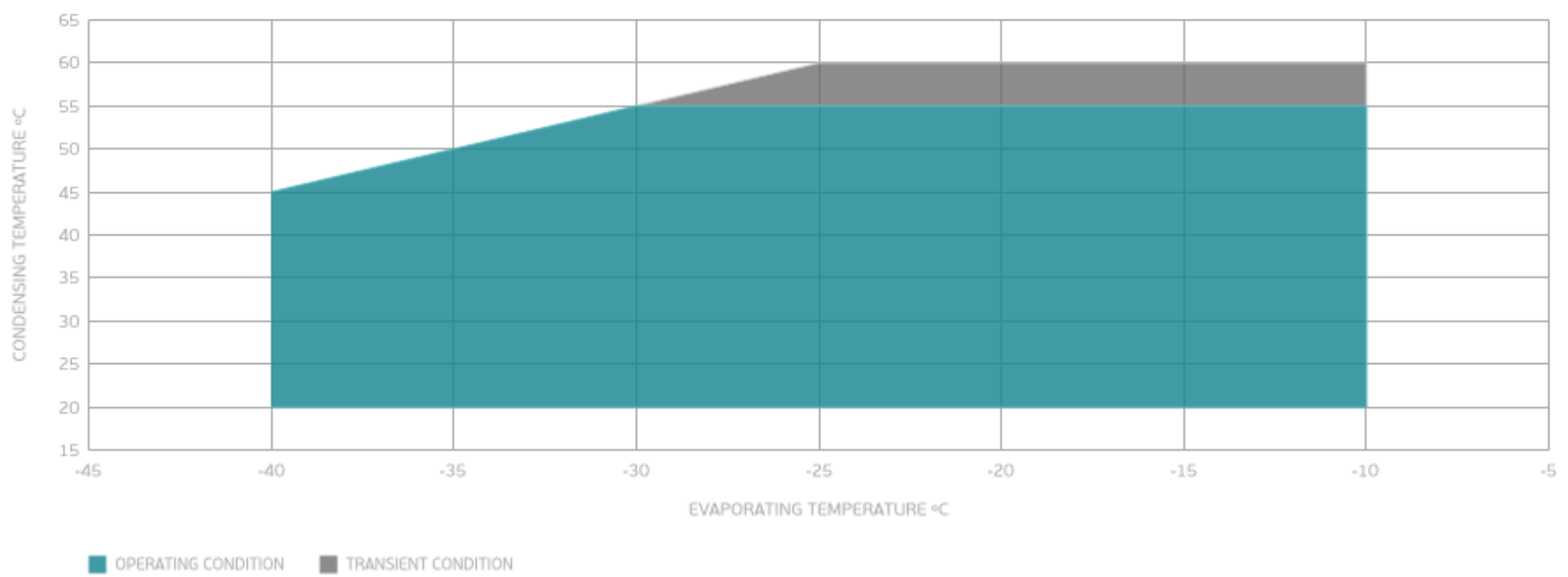

External

EXTERNAL CHARACTERISTICS

Base Plate		UNI	
Tray Holder		NO	
Connector	Internal Diameter	Shape	Material
Suction	8.1 mm	SLANTED 42°	COPPER
Discharge	6.45 mm	STRAIGHT	COPPER

EXTERNAL DIMENSIONS

SHELL

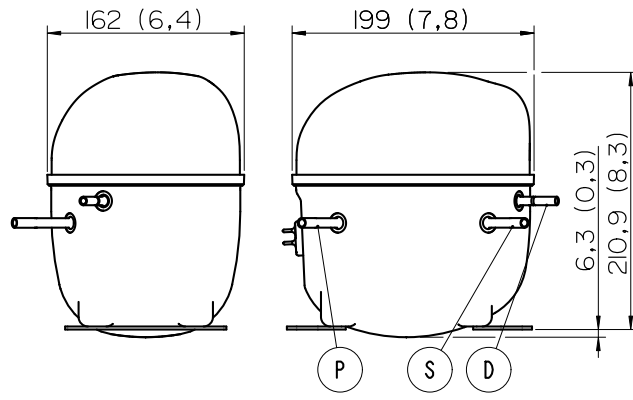

BASE

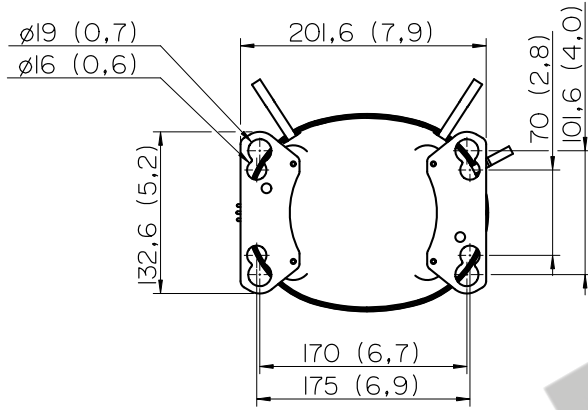

FENCE

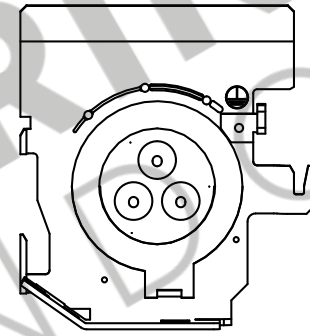

Telpon : (021) 80627021 , (021) 55787961
WhatsApp : 085722 611 888 (Chat Only)
Email : sales@polarin.co.id

PT. POLARIN XININDO

Pergudangan Duta Niaga No. 9BL/BK
Jl. Halim Perdana Kusuma
Jurumudi Baru, Benda - Tangerang 15124